

所有物质均符合环保要求

东莞市溪榜电子有限公司  
受控文件

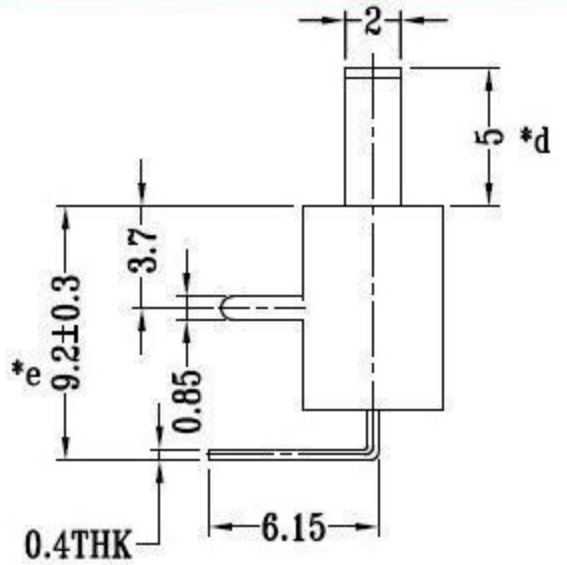

(胶头拨中间档位) 力度450±100gf

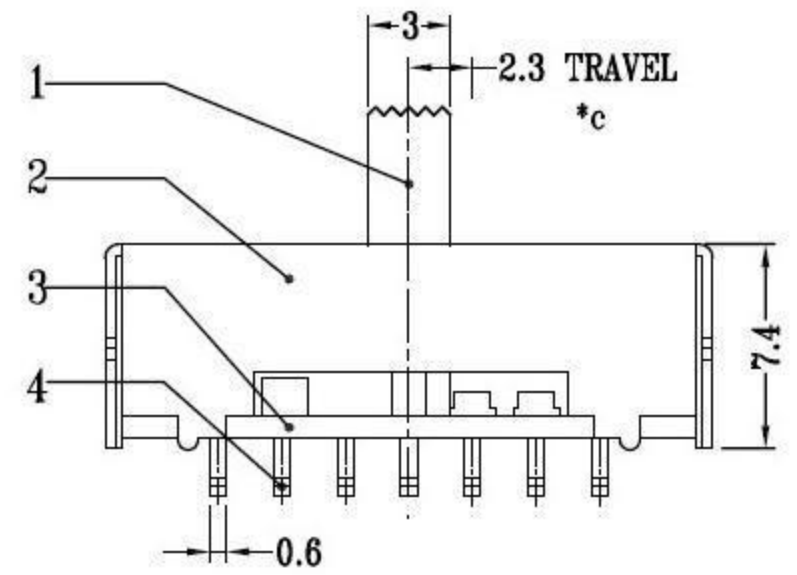
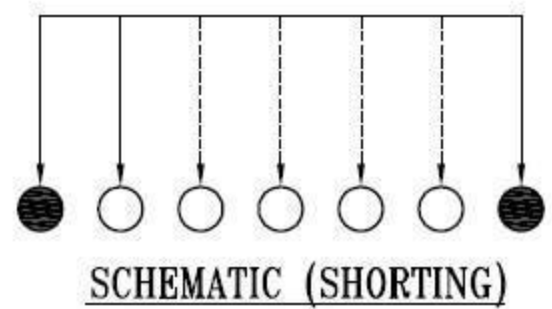
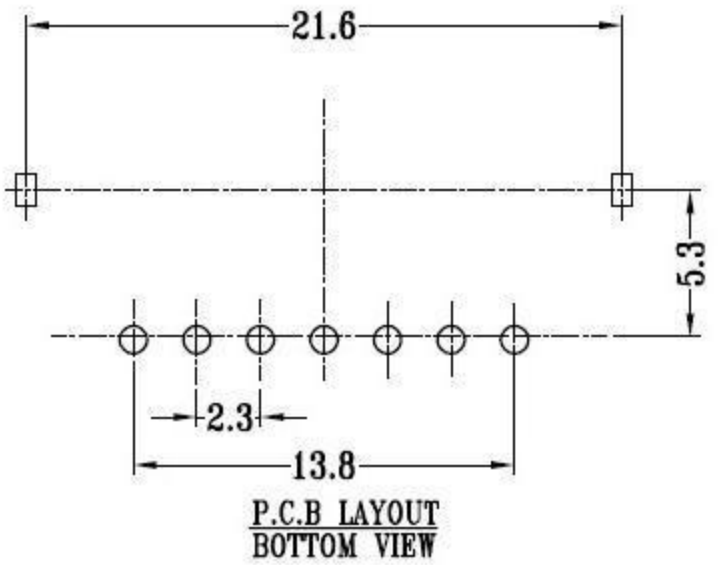
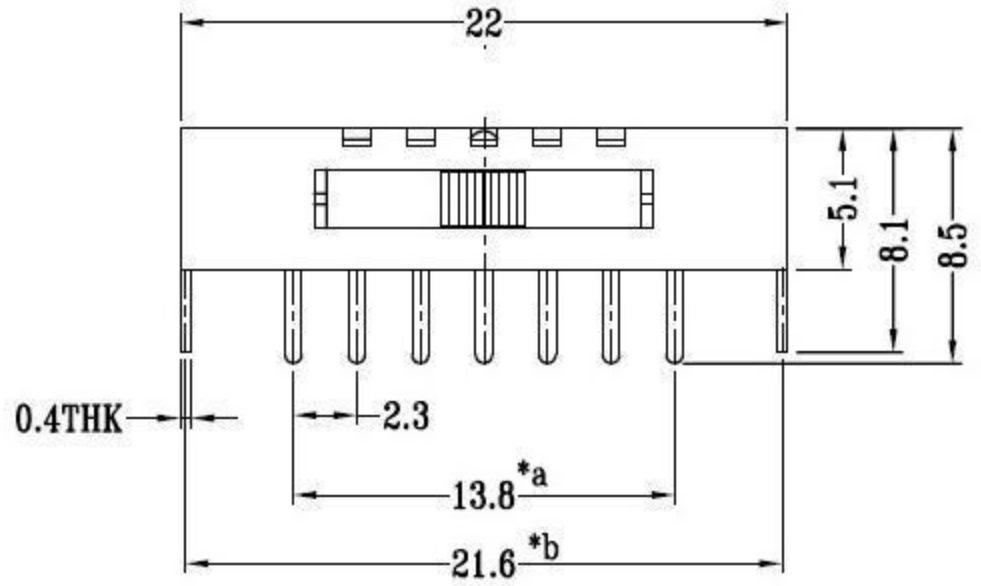

手柄X位置, 与操作力按照用户需求定制!

8					TOLERANCE				
7	STEEL BALL	STEEL	2	NATURAL	UNLESS SPECIFIED				
6	SPRING	STEEL WIRE	1	NATURAL	WITHIN	A	2010-01-02	初版	
5	CONTACT CLIP	PBS STRIP	2	Ag PLATED	OVER	ISSUE	DATE	DESCRIPTIONS OF REVISION	APPD.
4	TERMINAL	BRASS STRIP	8	Ag PLATED	TITLE : SLIDE SWITCH			UNIT : mm	DRWG NO.:
3	BASE	PHENOLIC RESIN	1	NATURAL	MODEL:			SCALE: 2:1	DWN.
2	FRAME	STEEL STRIP	1	Ni PLATED	东莞市高迪电子有限公司				2010-01-02
1	KNOB	POM	1	BLACK					2010-01-02
NO.	PARTS	MATERIALS	Q'TY	FINISH				CHK'D	
								APPD.	